



## Street furniture technical specifications

"MODERN" range

# Bench Fontainebleau 2



JBC-0023



JBC-0023

### MODERN range:

The "Modern" range is based on a simple, straightforward composition with a discrete base and solid wooden square slats. The plain and unadorned "Modern" range can be integrated long-term into any type of landscape.

**+ Ideas:** Full attention has been given to the base of the "Modern" range to make it as discrete as possible without losing any of its stability.

**+ Design:** The strong visual presence of the bench is created by its shape, thickness and the materials used to make it. These benches are as welcoming as they are reassuring.

**+ Quality:** The seats are made of softwood or tropical hardwood, also known as "ironwood" due to its exceptional resistance and attractive appearance.

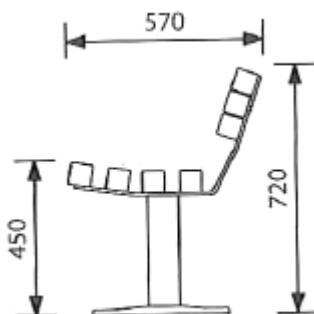

### Identification:

Catalogue	Street furniture
Range	Modern
Pages	32

### Dimensional characteristics:

Equipment dimensions (LxWxH)	2000x570x720 mm
Seat length	2000 mm
Seat height	450 mm
Number of places	4
Number of slats	7
Slat section (LxH)	70x70 mm
Weight	88 Kg

### Material:

Base	Galvanised, painted steel
Seat	Hardwood or softwood (depending on version)
Back	Hardwood or softwood (depending on version)

### Standard:

NF EN 335-1	Class 4
NF P 99-610	Yes

### Installation:

Delivery	Kit
Fixing type	Foundation bolts/pins

### Colour:

Standard base colour *	Black RAL 9005
Standard seat and back colours	Light oak

\* more than 200 shades available on request





## Street furniture



### + STEEL

#### **Extremely resistant double coating**

All our steel sections feature double-surface coating:

- Treatment 1: hot-dip galvanisation after manufacture (on the inside and outside of the tubes)
- Treatment 2: powder coating (oven-cured powder paint)

This double treatment guarantees optimum protection from corrosion.



### + IRON OR ALUMINIUM CASTING

#### **Efficient method**

After being removed from the mould, the cast iron or aluminium parts are stripped, sand-blasted and then coated in oven-cured polyester powder at a temperature of 250°C to form a uniform, protective coat of approximately 100 microns.



### + ASSEMBLY

#### **Stainless steel bolts and screws**

For the metal assemblies, we systematically use our special vandal-resistant bolts which cannot be unscrewed without a special HUSSON tool.

For the wooden/metal assemblies, we have also developed a special vandal-resistant stainless steel screw.



### + GUARANTEE

#### **Long-term guarantee**

Thanks to the quality of the materials used and to our double surface treatment, our furniture is designed to withstand the harshest climates and vandalism, thus guaranteeing the sustainability of investments.



### + WOOD AND POLYMERS

#### **Many possibilities to meet every requirement**

- **Tropical hardwood** ("ironwood"): We have chosen an extremely tough tropical hardwood ("ironwood") for its exceptional resistance and attractive appearance. As part of its sustainable development approach, HUSSON International is committed to using wood harvested from forests which are managed in an environmentally responsible manner.
- **Softwood**: Cheaper than hardwood, the softwood selected by HUSSON International has a very attractive appearance and is the number one choice.
- **Recycled materials**: As part of its sustainable development approach, HUSSON International uses recycled materials for its bench slats and litter bins. The selected materials are extremely stain- and scratch-resistant and reduce maintenance to a bare minimum ==> See "WoodTech" technical specification sheet.
- **HPL** (High Pressure Laminate): Extremely tough and wear-resistant, flame-retardant, volume-dyed, easy maintenance, high pressure laminate. Available with a wooden texture for a beautiful effect.
- **Rotation moulded polymers**: The planter and litter bin tubs and some of the street furniture items are made of polymers, generally HDPE (High Density Polyethylene) or PP (Polypropylene). Rotation moulding technology is used to create mechanically-resistant, volume dyed products with complex shapes.



### + WOOD SURFACE TREATMENT

#### **Environmentally-friendly treatment**

(For softwood and hardwood)

To improve the long-term durability of the surface coating, and to facilitate their maintenance, we use a vacuum and pressure surface-coating treatment which enables excellent penetration into the wood.

Results:

- Clearly improved durability
- Extremely easy maintenance
- Environmentally-friendly, solvent-free treatment which is safe for users