



MODULAR SEATS

Inclusive game



PRODUCT INFORMATION

Reference	Product designation	Universe	Age (years)	Impact Area (m ²)	Maximum Fall Height (m)	Dimensions		Number of users (pers.)	Number of activities
						Equipment (L x W x H in m)	Safety zone (L x W in m)		
JJM-2148	Mini Swing Bird's Nest Flower	Towns & Villages	2+	15.28	1.5	2,40m x 1,87m x 2,54m	2,25m x 6,79m	4	3



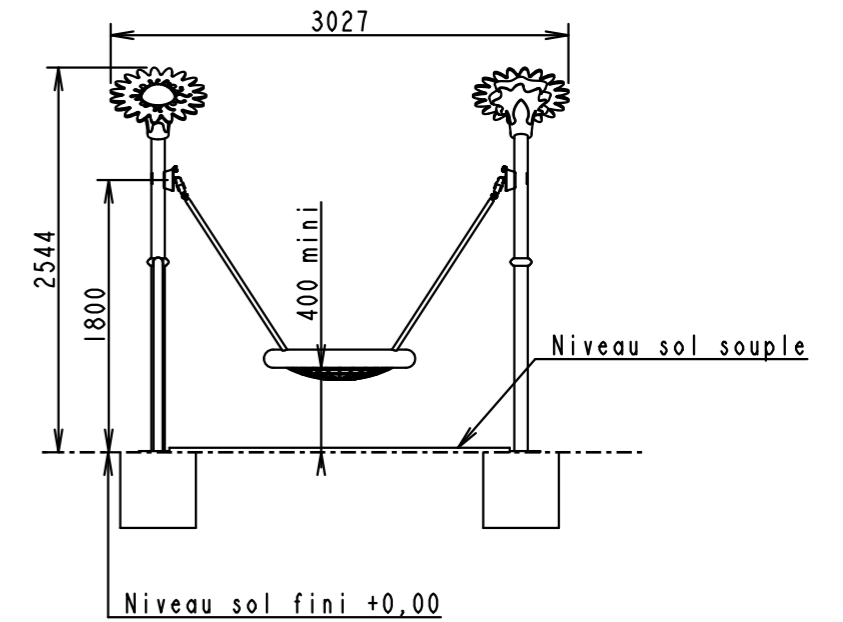
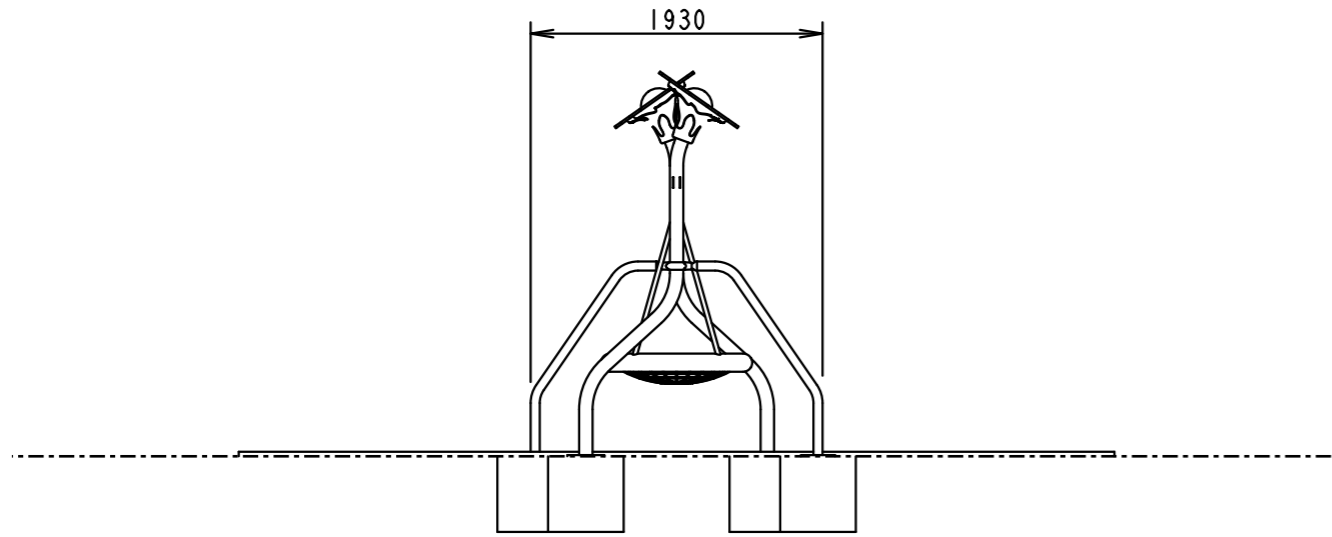

DÉTAIL DE SCELLEMENT

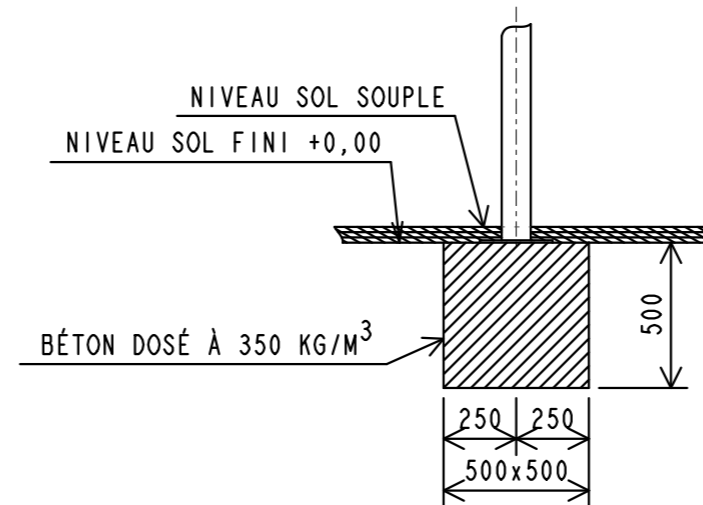

COUPE PLOTS-PLOTS

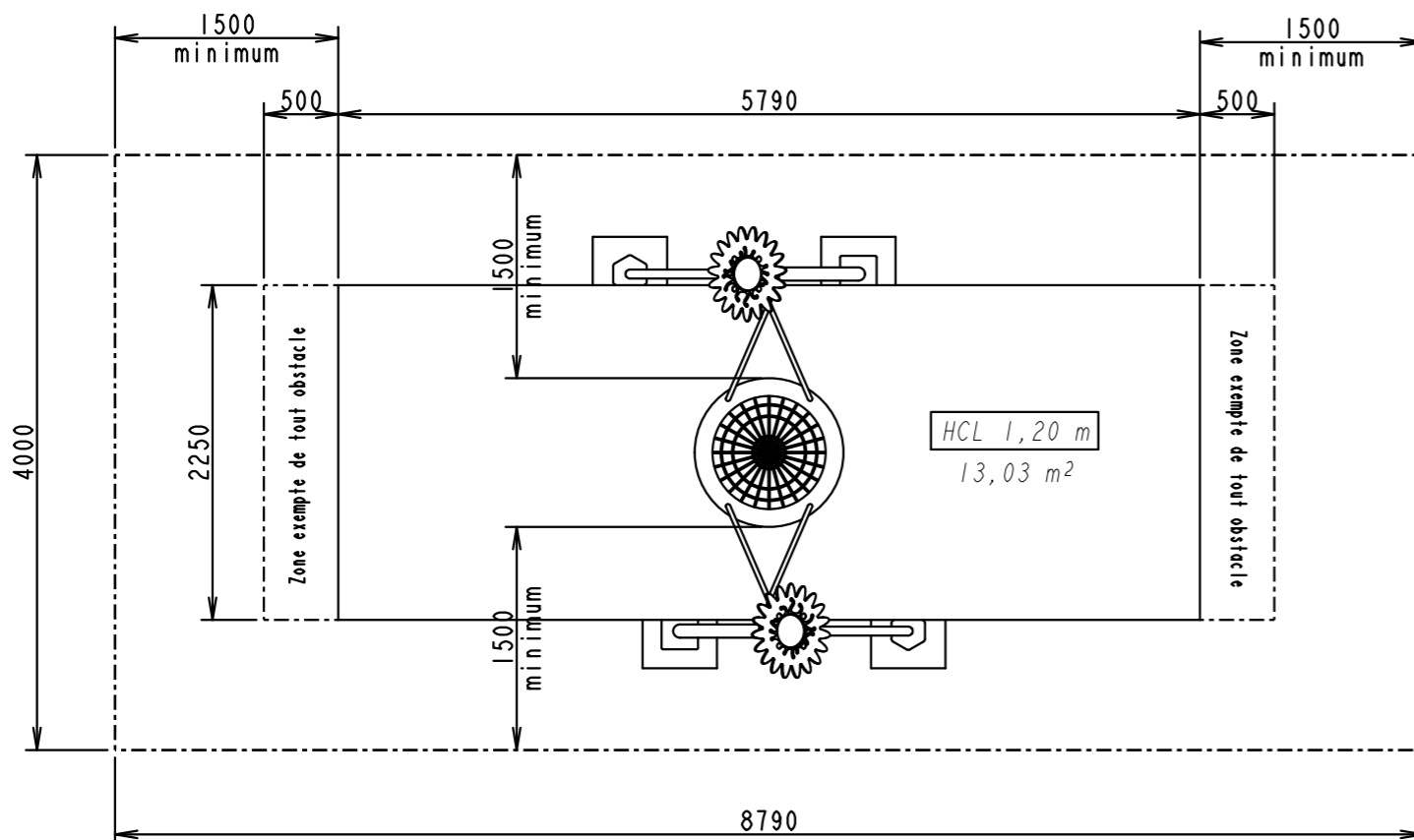
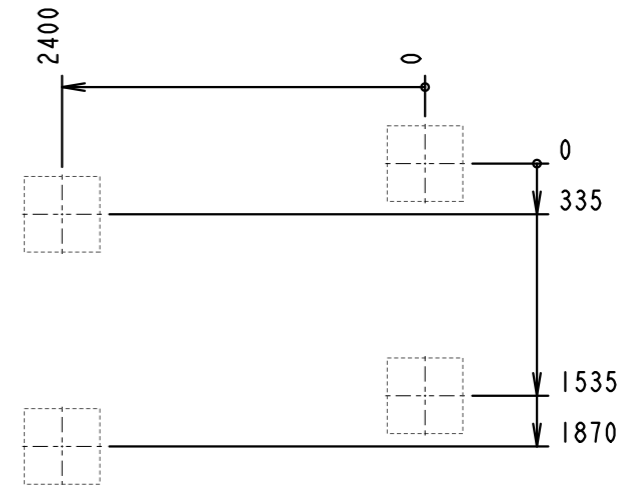

Dimensions minimum clôture et exempte de tout obstacle Norme EN1176-2-2017 annexe A

!! IMPORTANT !!

Réaliser les fondations impérativement 15 jours avant le montage. Respecter les distances de sécurité autour du jeu.

CRÉATION DE L'ENSEMBLE		A	16-May-24	TBesserer
MODIFICATIONS		RÉV	DATE	AUTEUR
<p>PORTIQUE MINI NID FLEUR Niv.0 JJM-2148-00</p> <p>PLAN D'ENCOMBREMENT / TOP VIEW / DRAUFSICHT PLAN DE SCELLEMENT / FOUNDATION DRAWING / FUNDAMENTIERUNGSPLAN</p>				
Dessiné par : TBesserer	Le : 16-May-24	Éch. 1:50		
Vérifié par : -	Rév : A.1 Conception	Page : 1/2		
				A3





MATERIAL SPECIFICATIONS



Hot-dip galvanized steel frames (inside and outside) + Powder Coating (oven-baked polyester powder paint) : Made from 89 mm diameter, 2.9 mm thick E24-grade steel tubes, hot-dip galvanized (immersed in molten zinc) and powder-coated to ensure long-lasting durability against weathering.

The paint is non-toxic for humans and the environment — free from lead and solvents (in compliance with European Directives 67/548/EEC and 99/45/EC).



Many components made entirely of stainless steel, Made from passivated 304L stainless steel, diameter 34 mm or 89 mm depending on the equipment.



Platforms made of HPL (High-Pressure Laminate), **highly durable (14 mm thick)**, rot-proof, and flame-retardant, mounted on a metal frame.

These platforms feature a specific non-slip surface coating.



Cladding panels made of HPL (High-Pressure Laminate), **highly durable** (14 mm thick), rot-proof, flame-retardant, and through-coloured (pigmented throughout the material).



Steel-core nets coated with a thick polyamide sheath: Made from mixed rope with 6 strands of 2.5 mm diameter each (total diameter = 16 mm).

Easy maintenance and repair of play components (ropes, steel parts) thanks to an exclusive assembly system that allows individual parts (ropes, connectors, etc.) to be replaced without needing to change the entire net structure.



Thermoplastic components (some slides, accessories, etc.): Complex-shaped components are manufactured using the rotomoulding technique.

For optimal durability, HUSSON uses only premium-quality materials such as thick, through-coloured HDPE (High-Density Polyethylene), which are easy to maintain.



Assembly: Using multidirectional cast aluminum clamps. The assembly system is standardized across the entire HUSSON range, ensuring easy maintenance.

Each component can be disassembled individually and replaced easily thanks to detailed assembly instructions. All parts are listed in a comprehensive parts list for easy identification. For example, HPL panels can be quickly swapped to ensure immediate safety.



MATERIAL SPECIFICATIONS



Fixings: The nature of our fixings (stainless steel screws embedded in cast aluminum clamps) ensures complete safety during play, without the need for removable screw covers—which, based on experience, tend to come off easily and cause recurring issues.

Our equipment is mounted on base plates, making installation adjustments easier and allowing the play area to be relocated if necessary.



Safety: Husson play equipment is designed in compliance with the latest European standards EN 1176 (2017 version) and decree No. 94-699.

This conformity is ensured through inspections and certifications carried out by an independent testing laboratory. Going beyond the required standards and regulations, Husson equipment often exceeds safety expectations, for example regarding: the strength of the frames, anti-fall connection guardrails, and ergonomic design of access points and bridges.

Thanks to the use of materials that are extremely resistant to weather conditions and selected for intensive free access use, **all our equipment benefits from a long-term warranty.**

Warranty: A long-term warranty of 10 years.

Covered parts: metal framework (posts and assembly parts), HPL panels, platforms. **Warranty conditions:** Please refer to the HUSSON general terms and conditions of sale (found in the last pages of the current price list).



Specific features

» MAGICOLOR RANGE:



- **Frame / Structure:** A 100% stainless steel frame with a diameter of 33.7 mm. Synonymous with high quality, stainless steel itself guarantees longevity and offers the simplest and most economical maintenance.

- **Pre-assembled Equipment:** A unique concept — compact play structures delivered pre-assembled (factory-mounted) for ultra-fast, hassle-free installation.



» SOLO + SWING RANGE :



- **Chains:** An innovative anti-twisting system. The new system prevents the chains from twisting around the horizontal beam.

- **Modular:** Adaptable equipment. The frames can be modified to allow access for children with disabilities thanks to specific seats available — please feel free to contact us.



» SOLO + SPRING RANGE :



- **Anti-pinch system:** The anti-pinch system, made of 2 cast aluminum fixing parts, is specifically designed to eliminate any risk of pinching and protrusions.

- **Efficient anchoring stake:** A practical and effective anchoring system allowing the stake to be simply buried in a 600 x 600 x 550 mm hole (without concrete).

